

10 9 8 7 6 5 4 3 2 1

F

E

D

C

B

A

- 1) DENTAL CHAIR w/ LIGHT & DELIVERY SYSTEM
- 2) SMOKE/ CO2 ALARM
- 3) SUCTION UNIT
- 4) BACK-UP CAMERA
- 5) 5lb FIRE EXTINGUISHER
- 6) AUTOCLAVE
- 7) ENTRY DOOR, SLIDING
- 8) ASSISTANT STOOL
- 9) DR STOOL
- 10) 60A 120VAC/12VDC POWER PANEL
- 11) ULTRASONIC CLEANER
- 12) 18" DRAWER CABINET
- 13) ACCESSORY STEP
- 14) WALLAROO FLIP DOWN SHELF
- 15) SHORE CABLE, 15M
- 16) HYDRAULIC PUMP w/ CONTROLS
- 17) ENTRY LIGHT
- 18) 13,500BTU ROOFTOP HVAC UNIT w/ HEAT
- 19) SPRINTER VAN
- 20) (4) 36"x30" OVERHEAD CABINETS
- 21) CORNER OVERHEAD CABINET
- 22) WORK SURFACE
- 23) GLOVE/ MASK DISPENSER
- 24) CARRY ON WATER BOTTLE C/F
- 25) CARRY OFF WASTE WATER TANK
- 26) SINK
- 27) DRIVER SEAT
- 28) PASSENGER/ RECEPTION SEAT
- 29) LEFT REAR DOOR
- 30) RIGHT REAR DOOR
- 31) 12"x 24" BASE CABINET WITH DRAWER
- 32) RADIO, AM/FM/CD/BT
- 33) WATER PUMP
- 34) DEMAND HOT WATER HEATER
- 35) DENTAL COMPRESSOR,
- 36) SHORE POWER RECEPTACLE
- 37) (4) LEVELING JACKS, HYDRAULIC
- 38) POWERED ROOF VENT
- 39) FOLDING SUN SHIELD
- 40) SOAP DISPENSER
- 41) HAND SANITIZER DISPENSER
- 42) EMERGENCY EXIT LIGHT
- 43) 7KW GASOLINE QUIET GENERATOR
- 44) SOUND INSULATED WALL
- 45) 5,200 BTU BASEBOARD HEATER
- 46) AMALGAM SEPARATOR
- 47) 13' x 8' POWERED AWNING (optional)

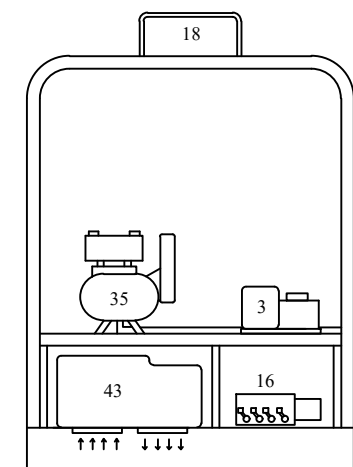
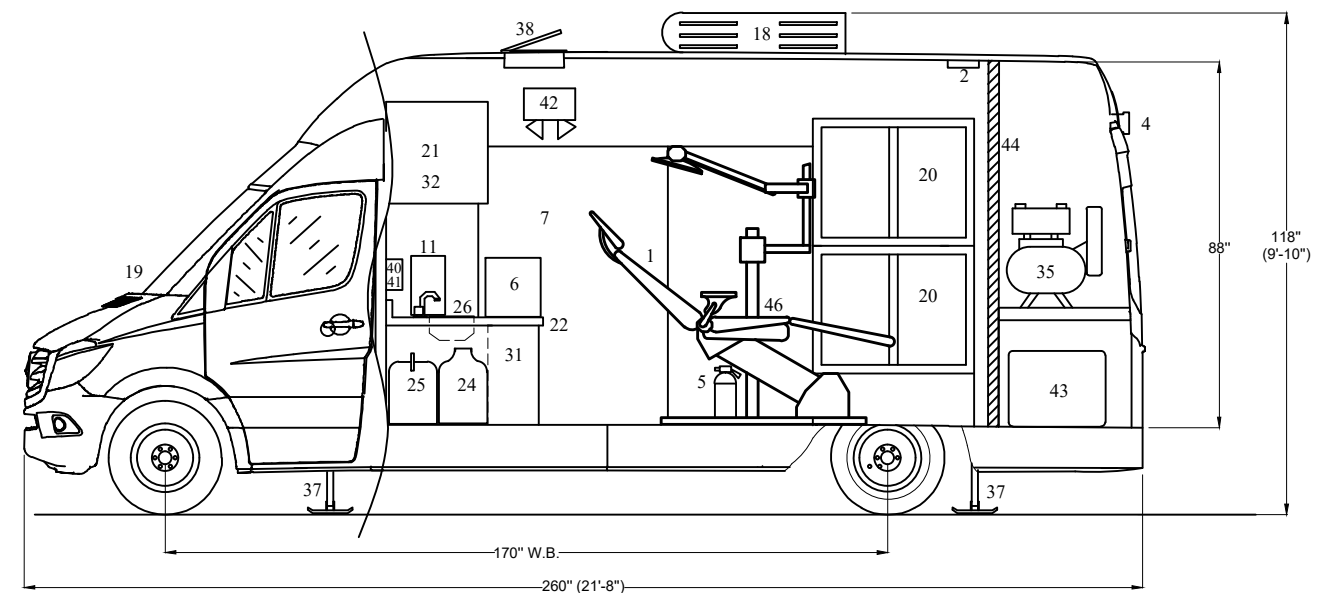
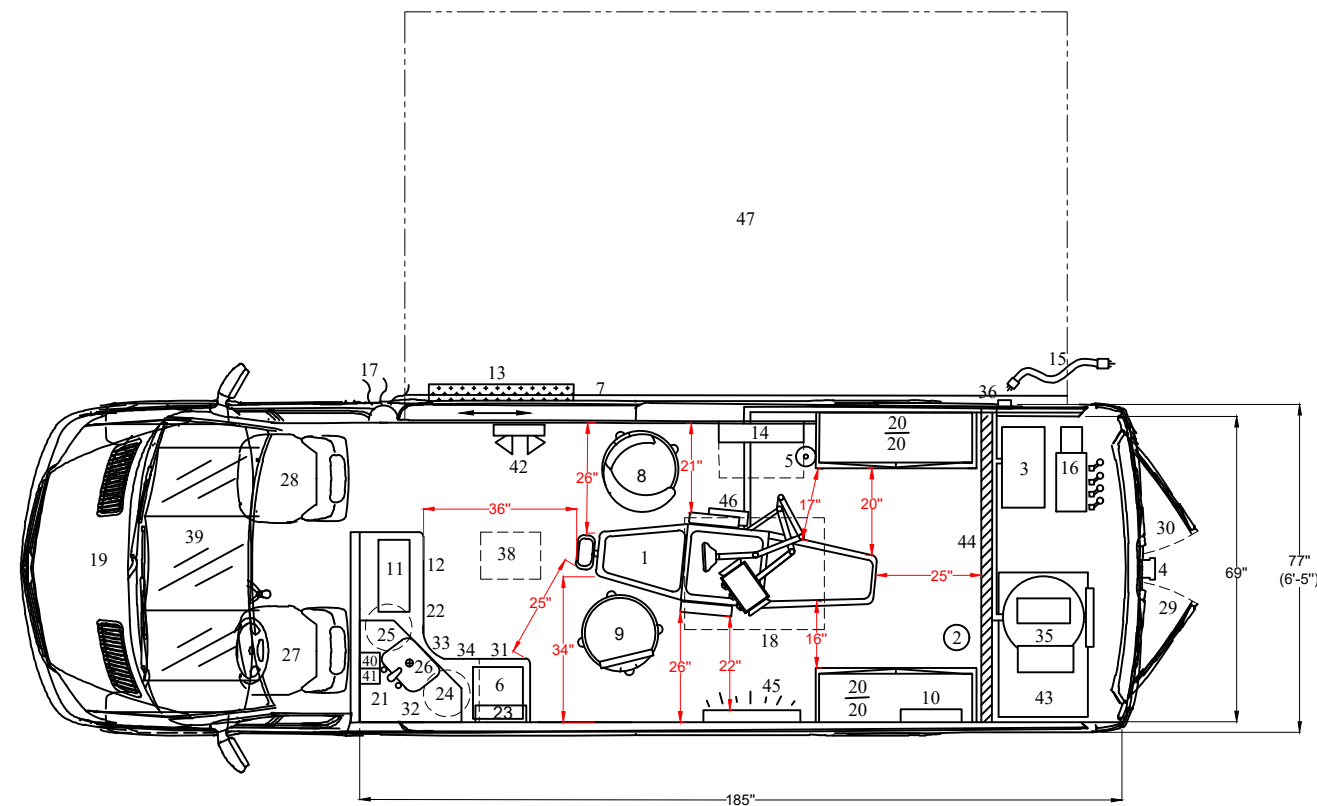

PROPRIETARY

THIS DRAWING WAS ORIGINATED BY AND IS THE EXCLUSIVE PROPERTY OF MOBILE CONVERSIONS INC. IT IS FURNISHED FOR RECIPIENT'S INFORMATION ONLY AND IS NOT AN AUTHORIZATION OR LICENSE TO MAKE THIS CONSTRUCTION OR TO FURNISH THIS TO OTHERS.

UNLESS OTHERWISE SPECIFIED: DIMENSIONS ARE IN INCHES TOLERANCES		CONTRACT NO.		MOBILE CONVERSIONS INC. 3354 STATE ROUTE 132, AMELIA, OH 45102 www.mobileconversions.com 513-797-1991	
FRAGMENTS DECIMALS IN MILLIARS X .XX ± .03X +.03 ± + XX.XXX ± .000X -.010		DRAWN BY: NICK SAMAD		DATE 09/21/2020	
MATERIAL --		CHECKED BY: --		TITLE ONE OPERATORY DENTAL SPRINTER VAN	
FINISH --		APPROVED BY: --		DWG. NO. 1001132C	
SIMILAR TO --		FILE: --		SCALE: --	
				RELEASE DATE: --	
				SHEET 1 OF 1	

10 9 8 7 6 5 4 3 2 1