

- 1) MAMMOGRAPHY UNIT
- 2) WORK STATION
- 3) (4) W3612 WALL CABINETS
- 4) (2) W3012 WALL CABINET
- 5) (2) W2730 WALL CABINETS
- 6) (2) 30" BASE CABINETS
- 7) 88" WORK SURFACE
- 8) (2) 24" POCKET DOORS
- 9) 30" INTERIOR DOOR
- 10) (2) BI-FOLD DOORS
- 11) (2) W3630 WALL CABINETS
- 12) (2) SETTEE w/ STORAGE
- 13) (2) 14' POWERED SLIDE OUT WITH FOLD UP FLOOR
- 14) (3) CHAIRS
- 15) W4230 WALL CABINET
- 16) 42" x 24" WORK SURFACE
- 17) OFFICE CHAIR
- 18) 24" x 84 PANTRY CABINET
- 19) PLATFORM STAIR SYSTEM w/ DETACHABLE HAND RAILS
- 20) 36" ENTRY DOOR w/ WINDOW
- 21) WHEEL CHAIR LIFT
- 22) (2) EXTERIOR LIGHTS
- 23) SHORE POWER CHORD COMPARTMENT
- 24) SHORE POWER CHORD 45'
- 25) 36,000 BTU HVAC UNIT/ 8 KW HEAT
- 26) 35 KW GENERATOR
- 27) HYDRAULIC COMPARTMENT
- 28) BATTERY
- 29) STORAGE COMPARTMENT
- 30) SMOKE DETECTOR
- 31) CO DETECTOR
- 32) 5LB. FIRE EXTINGUISHER
- 33) (2) COAT HOOKS
- 34) (2) MIRRORS
- 35) TRUCK CAB & CHASSIS
- 36) 10KVA UPS
- 37) POWER PANEL
- 38) (4) JACKS, LEVELING (NOT SHOWN)
- 39) W3318 WALL CABINET
- 40) HANDI-WIPES
- 41) 18" x 36" DARKENED WINDOW
- 42) WIND DEFLECTOR (optional)
- 43) 27" BASE CABINET
- 44) DIVIDER WALL w/ WINDOW
- 45) (2) HAND SANITIZER DISPENSERS
- 46) ROLL-UP DOOR
- 47) SERVICE ACCESS DOOR
- 48) TRANSFER SWITCH
- 49) LH FUEL FILL

NOTE: DIMENSIONS ARE APPROXIMATE

PROPRIETARY

THIS DRAWING WAS ORIGINATED BY AND IS THE EXCLUSIVE PROPERTY OF MOBILE CONVERSIONS INC. IT IS FURNISHED FOR RECIPIENT'S INFORMATION ONLY AND IS NOT AN AUTHORIZATION OR LICENSE TO MAKE THIS CONSTRUCTION OR TO FURNISH THIS TO OTHERS.

UNLESS OTHERWISE SPECIFIED: DIMENSIONS ARE IN INCHES TOLERANCES		CONTRACT NO. -		MOBILE CONVERSIONS, INC. CINCINNATI, OHIO www.mobileconversions.com	
DECIMALS .XX ± .03 .XXX ± .010	ANGULAR ±	DRAWN BY: NICK SAMAD	DATE 05/18/2017		
MATERIAL	---	CHECKED BY:	---	TITLE 39' MAMMOGRAPHY COACH	
FINISH	---	APPROVED BY:	---	SIZE B	CAGE CODE ---
SIMILAR TO	---	FILE:	---	DWG. NO. 1000831	RELEASE DATE: --
				SCALE:	SHEET 1 OF 2

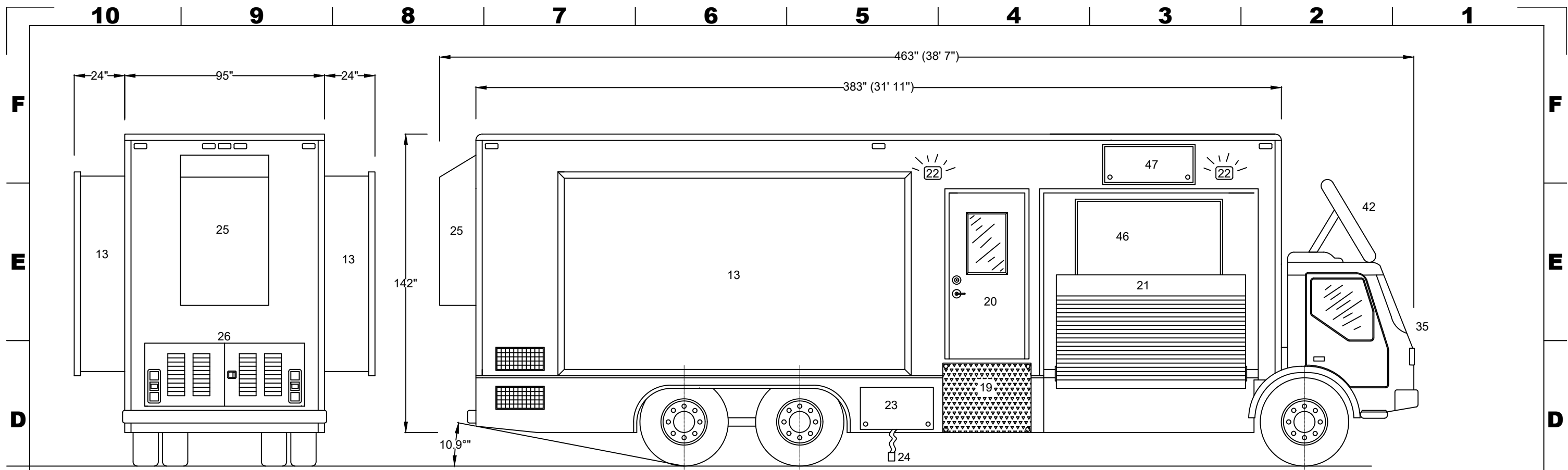

- 1) MAMMOGRAPHY UNIT
- 2) WORK STATION
- 3) (6) W3612 WALL CABINETS
- 4) (2) 3012 WALL CABINET
- 5) (2) W2730 WALL CABINETS
- 6) (2) 30" BASE CABINETS
- 7) 88" WORK SURFACE
- 8) (2) 24" POCKET DOORS
- 9) 30" INTERIOR DOOR
- 10) (2) BI-FOLD DOORS
- 11) (2) W3630 WALL CABINETS
- 12) SETTEE w/ STORAGE
- 13) (2) 14' POWERED SLIDE OUT WITH FOLD UP FLOOR
- 14) (3) CHAIRS
- 15) W4230 WALL CABINET
- 16) 42" x 24" WORK SURFACE
- 17) OFFICE CHAIR
- 18) 24" x 84" PANTRY CABINETS
- 19) PLATFORM STAIR SYSTEM w/ DETACHABLE HAND RAILS
- 20) 36" ENTRY DOOR w/ WINDOW
- 21) WHEEL CHAIR LIFT
- 22) (2) EXTERIOR LIGHT
- 23) SHORE POWER CHORD COMPARTMENT
- 24) SHORE POWER CHORD
- 25) 36,000 BTU HVAC UNIT/ 8 KW HEATER
- 26) 35 KW GENERATOR
- 27) HYDRAULIC COMPARTMENT
- 28) BATTERY
- 29) STORAGE COMPARTMENT
- 30) SMOKE DETECTOR
- 31) CO DETECTOR
- 32) 5LB. FIRE EXTINGUISHER
- 33) (2) COAT HOOKS
- 34) (2) MIRRORS
- 35) TRUCK CAB & CHASSIS
- 36) 10KVA UPS
- 37) POWER PANEL
- 38) (4) JACKS, LEVELING (NOT SHOWN)
- 39) W3318 WALL CABINET
- 40) HANDI-WIPES
- 41) 18" x 36" DARKENED WINDOW
- 42) WIND DEFLECTOR (optional)
- 43) 27" BASE CABINET
- 44) DIVIDER WALL w/ WINDOW
- 45) (2) HAND SANITIZER DISPENSERS
- 46) ROLL-UP DOOR
- 47) SERVICE ACCESS DOOR
- 48) TRANSFER SWITCH
- 49) LH FUEL FILL

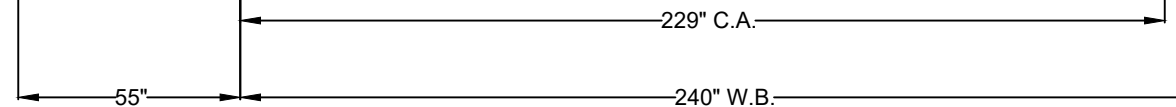

NOTE: DIMENSIONS ARE APPROXIMATE

PROPRIETARY

THIS DRAWING WAS ORIGINATED BY AND IS THE EXCLUSIVE PROPERTY OF MOBILE CONVERSIONS INC. IT IS FURNISHED FOR RECIPIENT'S INFORMATION ONLY AND IS NOT AN AUTHORIZATION OR LICENSE TO MAKE THIS CONSTRUCTION OR TO FURNISH THIS TO OTHERS.

UNLESS OTHERWISE SPECIFIED: DIMENSIONS ARE IN INCHES TOLERANCES		CONTRACT NO. -		MOBILE CONVERSIONS, INC. CINCINNATI, OHIO www.mobileconversions.com	
DECIMALS .XX ± .03 .XXX ± .010	ANGULAR ±	DRAWN BY: NICK SAMAD	DATE 05/18/2017	TITLE 39" MAMMOGRAPHY COACH	
MATERIAL --		CHECKED BY: --	--	SIZE B	CAGE CODE --
FINISH --		APPROVED BY: --	--	DWG. NO. 1000831	
SIMILAR TO --		FILE: --	--	SCALE: --	RELEASE DATE: --
				SHEET 2 OF 2	