

10 9 8 7 6 5 4 3 2 1

F

F

E

E

D

D

C

C

B

B

A

A

- 1) CHAIR w/ LIGHT
- 2) SMOKE/ CO2 ALARM
- 3) 13' x 8' POWERED AWNING (optional)
- 4) BACK-UP CAMERA
- 5) 5lb FIRE EXTINGUISHER
- 6) SOUND INSULATED WALL
- 7) ENTRY DOOR, SLIDING
- 8) ASSISTANT STOOL
- 9) DR STOOL
- 10) 60A 120VAC/12VDC POWER PANEL
- 11) 7 KW GASOLINE QUIET GENERATOR
- 12) STEPWELL COVER, HINGED
- 13) RUNNING BOARD STEP
- 14) LED, STRIP LIGHTS
- 15) SHORE CABLE, 45'
- 16) HYDRAULIC PUMP w/ CONTROLS
- 17) ENTRY LIGHT
- 18) 13,500BTU ROOFTOP HVAC UNIT w/ HEAT
- 19) SPRINTER VAN
- 20) (3) 36"x30" OVERHEAD CABINETS
- 21) 30" WALL CABINET(2)
- 22) 21" WORK SURFACE
- 23) GLOVE/ MASK DISPENSER
- 24) 25 GAL. FRESH WATER TANK
- 25) 31 GAL. WASTE WATER TANK
- 26) 15" WALL CABINET
- 27) DRIVER'S SEAT
- 28) PASSENGER'S SEAT
- 29) LEFT REAR DOOR
- 30) RIGHT REAR DOOR
- 31) RAISED COUNTERTOP
- 32) FULL WIDTH WORK SURFACE
- 33) WATER PUMP
- 34) DEMAND HOT WATER HEATER
- 35) 5,200 BTU HEATER
- 36) SHORE POWER RECEPTACLE
- 37) (4) LEVELING JACKS, HYDRAULIC
- 38) POWERED ROOF VENT
- 39) FOLDING SUN SHIELD
- 40) SOAP DISPENSER
- 41) HAND SANITIZER DISPENSER
- 42) UNDER COUNTER REFRIGERATOR (approx. 18" x 18")
- 43) FUTURE ASEPTIC SYSTEM
- 44) WINDOW w/ BLIND
- 45) 24" VANITY CABINET w/ SINK (shortened to 16" D)
- 46) CITY WATER FILL
- 47) 3" DUMP VALVE
- 48) (5) DRAWER CABINET
- 49) GRAB BAR

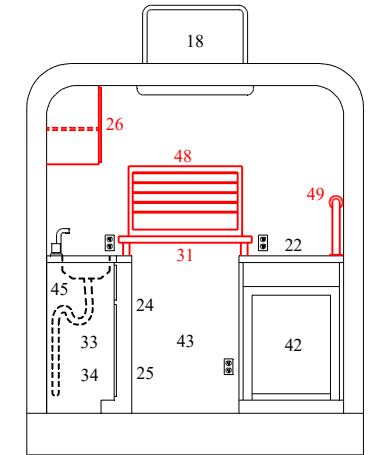
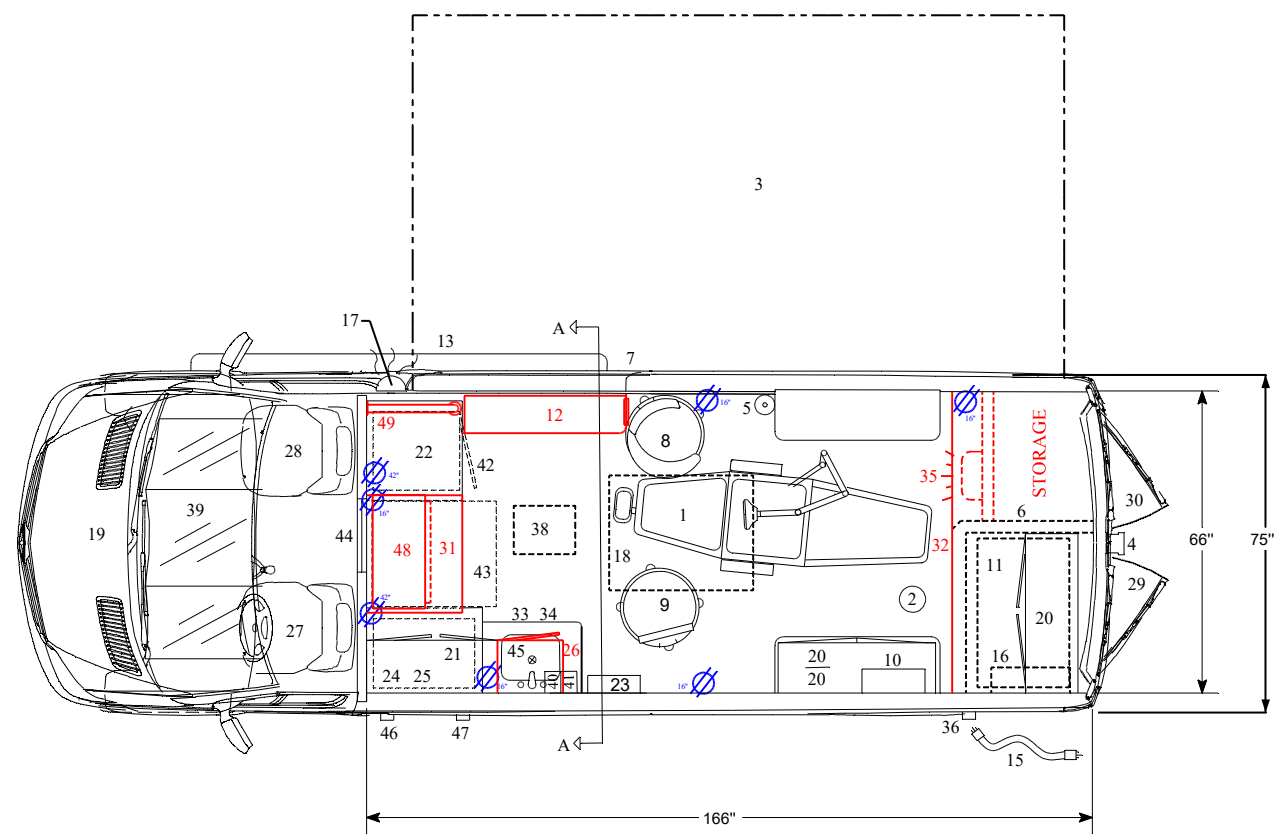

SECTION VIEW A-A

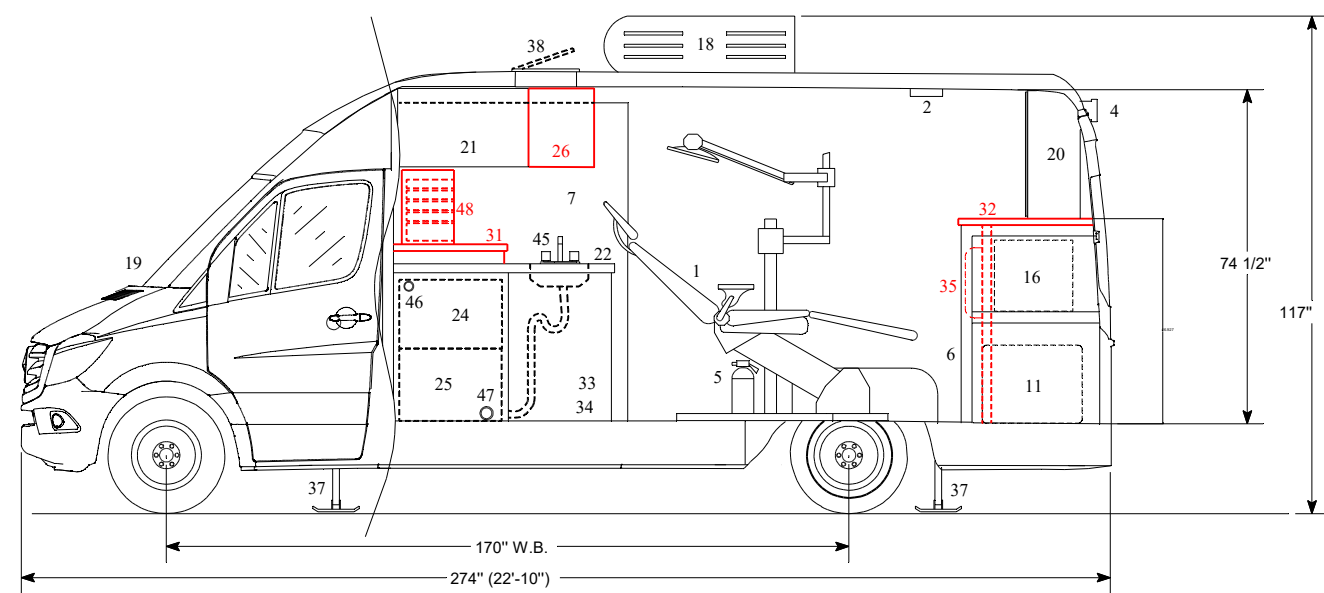

VIEW w/ STREET SIDE WALL REMOVED

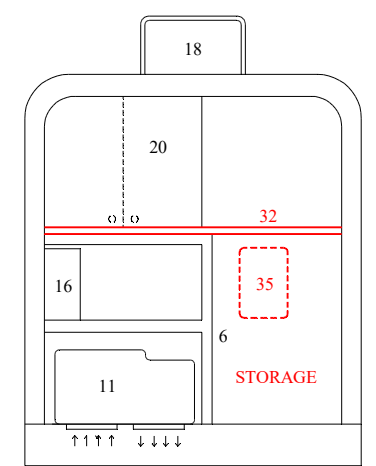

OUTSIDE VIEW w/ DOORS REMOVED LOOKING FORWARD.

**PROPRIETARY**

**THIS DRAWING WAS ORIGINATED BY AND IS THE EXCLUSIVE PROPERTY OF MOBILE CONVERSIONS INC. IT IS FURNISHED FOR RECIPIENT'S INFORMATION ONLY AND IS NOT AN AUTHORIZATION OR LICENSE TO MAKE THIS CONSTRUCTION OR TO FURNISH THIS TO OTHERS.**

|   |              |                                |                    |  |              |
|---|--------------|--------------------------------|--------------------|--|--------------|
| UNLESS OTHERWISE SPECIFIED:<br>DIMENSIONS ARE IN INCHES<br>TOLERANCES |              | CONTRACT NO.                   |                    | MOBILE CONVERSIONS INC.<br>3354 STATE ROUTE 132, AMELIA, OH 45102<br>www.mobileconversions.com<br>513-797-1991 |              |
| DECIMALS<br>.XX ± .03<br>.XXX ± .010                                  | ANGULAR<br>± | DRAWN BY:<br><b>NICK SAMAD</b> | DATE<br>02/10/2021 | TITLE<br><b>MEDICAL VAN</b>  |              |
| MATERIAL  | FINISH       | CHECKED BY:                    | APPROVED BY:       |  |              |
| SIMILAR TO  | FILE:        | DWG. NO.<br><b>1001132I</b>    |                    | SIZE<br><b>B</b>   | CAGE CODE    |
|   |              | SCALE:                         |                    | RELEASE DATE:  | SHEET 1 OF 1 |

10 9 8 7 6 5 4 3 2 1